



University of Pennsylvania
ScholarlyCommons

Publicly Accessible Penn Dissertations

2015

Q-Hit Polynomials Have Only Real Roots

Li-Ping Mo

University of Pennsylvania, sweetgab12@gmail.com

Follow this and additional works at: <https://repository.upenn.edu/edissertations>

 Part of the [Mathematics Commons](#)

Recommended Citation

Mo, Li-Ping, "Q-Hit Polynomials Have Only Real Roots" (2015). *Publicly Accessible Penn Dissertations*. 1906.

<https://repository.upenn.edu/edissertations/1906>

This paper is posted at ScholarlyCommons. <https://repository.upenn.edu/edissertations/1906>
For more information, please contact repository@pobox.upenn.edu.

Q-Hit Polynomials Have Only Real Roots

Abstract

We prove that Garsia and Remmel's q -hit polynomials for Ferrers boards have only real roots for fixed $q > 0$. This generalizes previous results by Haglund, Wagner and Ono [4] and Savage and Visontai [5]. We also extend the main recursion in [5] to hit polynomials for certain classes of Ferrers boards, which include the multiset Eulerian polynomials.

Degree Type

Dissertation

Degree Name

Doctor of Philosophy (PhD)

Graduate Group

Mathematics

First Advisor

James Haglund

Keywords

eulerian polynomials, Ferrers board, interlacing, q -hit polynomials, real-rooted, rook theory

Subject Categories

Mathematics

q -HIT POLYNOMIALS HAVE ONLY REAL ROOTS

Li-Ping Mo

A DISSERTATION

in

Mathematics

Presented to the Faculties of the University of Pennsylvania in Partial
Fulfillment of the Requirements for the Degree of Doctor of Philosophy

2015

Supervisor of Dissertation

James Haglund, Professor of Mathematics

Graduate Group Chairperson

David Harbater, Distinguished Professor in the School of Arts and
Sciences

Dissertation Committee:

James Haglund, Professor of Mathematics

Jennifer Morse, Professor of Mathematics

Tony Pantev, Professor of Mathematics, Undergraduate Chair

Acknowledgments

I would like to thank:

My adviser James Haglund, for introducing me to q -rook theory and a number of papers related to the topic, including [5] and [3] which my research is based on.

My parents, for their eternal, unwavering support.

ABSTRACT

q -HIT POLYNOMIALS HAVE ONLY REAL ROOTS

Li-Ping Mo

James Haglund

We prove that Garsia and Remmel's q -hit polynomials for Ferrers boards have only real roots for fixed $q > 0$. This generalizes previous results by Haglund, Wagner and Ono [4] and Savage and Visontai [5]. We also extend the main recursion in [5] to hit polynomials for certain classes of Ferrers boards, which include the multiset Eulerian polynomials.

Contents

1	Introduction	1
2	Properties of interlacing polynomials	14
3	Proof of Theorem 1.5	18
4	Proof of Theorem 1.20	24
5	Proof of Theorem 1.21	33
6	Special Cases	39

Chapter 1

Introduction

A *board* is any subset of the n -by- n array, $\{(i, j)\}_{1 \leq i, j \leq n}$, of *cells*; here we use the “matrix coordinates”, so (i, j) is on the i th row from top and the j th column from the left. A *placement* C of k (non-attacking) rooks on a board B is a subset of B with cardinality k such that no two cells in C share a row or a column, and we denote the set of all such placements by $P_k(B)$. The k th *rook number* of B , $r_k(B)$, is the cardinality of $P_k(B)$, or in other words, the number of ways of placing k non-attacking rooks on B .

Let P_n be the set of all $n!$ placements of n rooks on the entire n -by- n array. For any placement $C \in P_n$, we set $h_B(C) = \#B \cap C =$ number of rooks in C that are on B . The *hit polynomial* $H_n^B(x)$ is the generating function of the statistic h_B on P_n :

$$H_n^B(x) = \sum_{C \in P_n} x^{h_B(C)}. \quad (1.1)$$

The coefficient of x^k in $H_n^B(x)$ is called the k th *hit number* of B , and it is the number

of ways of placing n rooks on the n -by- n array such that there are exactly k rooks on B .

There is a basic relation between rook numbers and hit polynomials (see for example [1], Section 2):

Theorem 1.1. *For any board B ,*

$$H_n^B(x) = \sum_{k=0}^n r_k(B)(n-k)!(x-1)^k. \quad (1.2)$$

A *Ferrers board* is a board B such that any cell above or to the right of a cell in B is also in B . Any Ferrers board is uniquely determined by its weakly increasing sequence of column lengths (c_1, \dots, c_n) . See Figure 1.1 for the Ferrers board corresponding to the sequence $(0, 1, 1, 2, 3)$. For a Ferrers board, there is a direct relation between its sequence of column lengths and its rook numbers.

Theorem 1.2. *Given Ferrers board B with column lengths $c_1 \leq \dots \leq c_n$, we have*

$$\sum_{k=0}^n r_k(B)x(x-1)\dots(x-n+k+1) = \prod_{i=1}^n (x+c_i-i+1). \quad (1.3)$$

A combinatorial proof of this theorem can be found in Sec. 2.4 of [6]. The idea of the proof is to consider B^x , the Ferrers board with column lengths (c_1+x, \dots, c_n+x) .

¹ Both sides of the equation count $r_n(B^x)$.

Since $1, x, x(x-1), \dots, x(x-1)\dots(x-n+1)$ are linearly independent, it follows from (1.3) that two Ferrers boards with column lengths (c_1, \dots, c_n) and (c'_1, \dots, c'_n) have

¹Rook numbers do not depend on n ; hence we do not require $c_n+x \leq n$ here. The stricter definition of a Ferrers board we use (where the longest column is at most n) is usually referred to as an *admissible* Ferrers board in the literature.

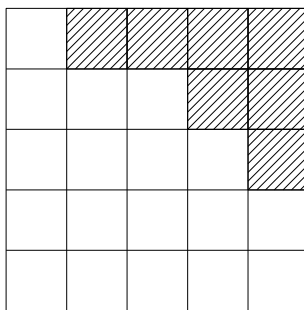

Figure 1.1: Ferrers board corresponding to $(0, 1, 1, 2, 3)$.

identical rook numbers (and hence identical hit polynomials because of (1.2)) iff the two multisets $\{c_i - i + 1\}_{i=1,\dots,n}$ and $\{c'_i - i + 1\}_{i=1,\dots,n}$ are the same. For example, the two boards $(0, 1, 1, 2, 3)$ and $(0, 0, 1, 2, 4)$ have identical rook and hit polynomials since they both give the multiset $\{0^2, (-1)^3\}$. We say such two Ferrers boards are *Ferrers equivalent*. (See also [6], Sec. 2.4). For two boards in general, we say they are *equivalent* if they have the same hit polynomial. For example, permuting the rows (or columns) of a board results in an equivalent board.

In their paper [3], Garsia and Remmel developed q -analogs of the rook numbers and hit polynomials for Ferrers boards. These reduce to the usual rook numbers and hit polynomials when q is set to 1. The q -rook numbers are defined as $r_k(B, q) =$

$\sum_{C \in P_k(B)} q^{\text{inv}(C)}$, where $\text{inv}(C)$ is the number of cells on B that do not hold a rook, is

not directly above a rook in C , and is not to the right of a rook in C . (See Figure 1.2)

They were then able to prove a q -version of Theorem 1.2 for their q -rook numbers:

Theorem 1.3. *Given Ferrers board B with column lengths $c_1 \leq \dots \leq c_n$, we have for*

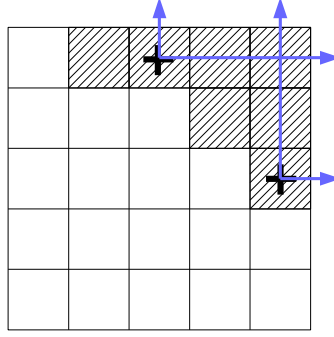

Figure 1.2: Computation of $inv_B(C)$. From each rook (represented by the plus sign), we cross off all cells above it and all cells to the right of it. There are two cells of B remaining, so $inv_B(C) = 2$.

$x \in \mathbb{N}$,

$$\sum_{k=0}^n r_k(B, q)[x][x-1]\dots[x-n+k+1] = \prod_{i=1}^n [x+c_i-i+1] \quad (1.4)$$

where $[a]$ denotes $1 + q + \dots + q^{a-1}$.

This is Equation 1.3 in [3], and the proof uses the same technique as the proof of Theorem 1.2. The two sides of the equation now count $r_n(B^x, q)$.

The following version of *q-hit polynomial* appears in [3]:

$$Q_B(x, q) = \sum_{k=0}^n r_{n-k}(B, q)x^k[k]!(1-xq^{k+1})\dots(1-xq^n), \quad (1.5)$$

for any Ferrers board B . As in [1], we will reverse the order of coefficients of $Q_B(x, q)$ as a polynomial in x and define

$$H_n^B(x, q) = \sum_{k=0}^n r_k(B, q)[n-k]!(x-q^{n-k+1})\dots(x-q^n) = x^n Q_B(x^{-1}, q). \quad (1.6)$$

Note that (1.6) reduces to (1.2) when $q = 1$.

Corollary 1.4. *The q -rook numbers $r_k(B, q)$ and the q -hit polynomial $H_n^B(x, q)$ of a Ferrers board B are uniquely determined by the column lengths c_1, \dots, c_n of B . Consequently, equivalent Ferrers boards have identical q -rook numbers and q -hit polynomial.*

Proof. The $r_k(B, q)$ part follows from (1.3) and that $1, [x], [x][x-1], \dots$ are linearly independent. (See Section 1, [3].) The $H_n^B(x, q)$ part then follows from (1.6). \square

In the same paper [3], Garsia and Remmel derived the following identity for the q -hit polynomials:

$$\sum_{k \geq 0} x^k [k + c_1] \dots [k + c_n - n + 1] = \frac{Q_B(x, q)}{(1-x)(1-xq) \dots (1-xq^n)} \quad (1.7)$$

There are combinatorial interpretations of $H_n^B(x, q)$, for example via the ξ statistic in [1]. This statistic will be defined in Chapter 4.

The first main result of this paper, whose proof will be given in Chapter 3, is

Theorem 1.5. *Let B be a Ferrers board in the n -by- n array, and let $q > 0$. Then $Q_B(x, q)$ and $H_n^B(x, q)$ have only real roots.*

The $q = 1$ case states that the ordinary hit polynomials $H_n^B(x, 1)$ have only real roots for any Ferrers board B ; this was known (see [4], Theorem 1).

The hit polynomials have a natural interpretation in terms of permutations. We identify S_n with P_n by sending the permutation $\sigma = \sigma_1 \sigma_2 \dots \sigma_n \in S_n$ to the placement $C(\sigma) = \{(1, \sigma_1), (2, \sigma_2), \dots, (n, \sigma_n)\}$. Then we can also talk about $h_B(\sigma) = h_B(C(\sigma)) = \#\{i | (i, \sigma_i) \in B\}$. We then have $H_n^B(x) = \sum_{\sigma \in S_n} x^{h_B(\sigma)}$. In particular,

when the board B is the upper triangular board with column lengths $(0, 1, \dots, n - 1)$, we get $h_B(\sigma) = exc(\sigma) := \#\{i \in [1, n] \mid \sigma_i > i\}$, the *excedance* statistic.

The *Eulerian polynomials* are defined as

$$E_n(x) = \sum_{\sigma \in S_n} x^{des(\sigma)}, \quad (1.8)$$

where if $\sigma = \sigma_1 \dots \sigma_n$, $des(\sigma) := \#\{i \in [1, n - 1] \mid \sigma_i > \sigma_{i+1}\}$. There is a well-known bijection $\phi : S_n \rightarrow S_n$ that takes des to exc ; see for example [6], Sec 1.3. Given $\sigma = \sigma_1 \sigma_2 \dots \sigma_n \in S_n$, we mark any element that is larger than all elements to its left. We insert left parentheses before these elements, and right parentheses as appropriate, and then view it as a new permutation $\sigma' \in S_n$ in cycle notation. We set $\phi(\sigma) = (\sigma')^{-1}$. For example, if $\sigma = 41352 \in S_5$, then $\sigma' = (413)(52)$, and so $\phi(\sigma) = (431)(52) = 45132$. One property of ϕ is that for any i such that $\sigma_i > \sigma_{i+1}$, we have $\phi(\sigma)_j = \sigma_i$ where $j := \sigma_{i+1}$. In particular we have $des(\sigma) = exc(\phi(\sigma))$, so

$$E_n(x) = \sum_{\sigma \in S_n} x^{exc(\sigma)} \quad (1.9)$$

is also the generating function for exc . Hence Eulerian polynomials are a special case of hit polynomials:

Theorem 1.6. *Let B be the upper triangular board. Then $E_n(x) = H_n^B(x)$.*

Proposition 1.7. *For any Ferrers board B contained in the upper triangular board, we have*

$$H_n^B(x) = \sum_{\sigma \in S_n} x^{des_B(\sigma)}, \quad (1.10)$$

where $des_B(\sigma) := \#\{i \in [1, n - 1] \mid (\sigma_{i+1}, \sigma_i) \in B\}$.

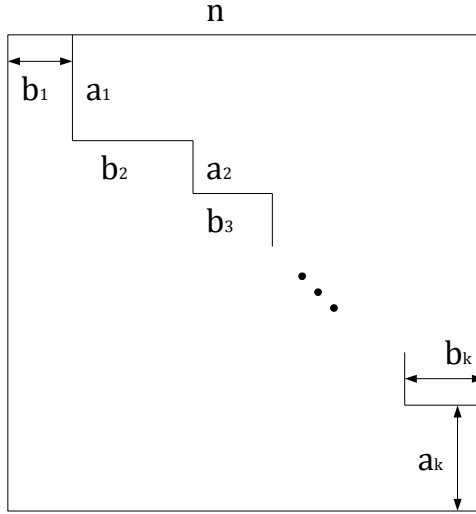

Figure 1.3: The board $B_n(b_1, a_1; b_2, a_2; \dots; b_k, a_k)$.

There are many generalizations of the Eulerian polynomials. For any $r \geq 1$, we define the r -Eulerian polynomials $E_n^r(x) = \sum_{\sigma \in S_n} x^{\text{des}_r(\sigma)}$, where $\text{des}_r(\sigma) := \#\{i \in [1, n-1] \mid \sigma_i \geq \sigma_{i+1} + r\}$. We also define the multiset Eulerian polynomial $E_M(x) = \sum_{\sigma \in S_M} x^{\text{des}(\sigma)}$ for any multiset $M = \{1^{a_1}, \dots, k^{a_k}\}$. Here S_M is the set of multiset permutations, i.e. distinct ways of writing a_1 1's, ..., and a_k k 's in a row.

Definition 1.8. For $\sum_{i=1}^k b_i = \sum_{i=1}^k a_i = n$, let $B_n(b_1, a_1; b_2, a_2; \dots; b_k, a_k)$ be the board shown in Figure 1.3. When we want to focus on the board itself without mentioning n , we also write the above as $B(-, a_1; b_2, a_2; \dots; b_{k-1}, a_{k-1}; b_k, -)$.

Remark 1.9. Any Ferrers board can be expressed as $B_n(b_1, a_1; \dots; b_k, a_k)$ for some k and some $b_2, \dots, b_k \geq 1$ and $a_1, \dots, a_{k-1} \geq 1$, and we will assume this to be the case

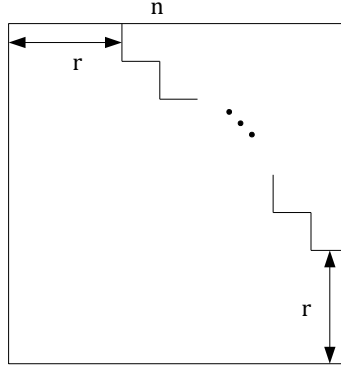

Figure 1.4: Board associated with the r -Eulerian polynomials.

whenever we write specify an arbitrary Ferrers board as $B_n(b_1, a_1; \dots; b_k, a_k)$. When a board is expressed this way, it contains (n, n) iff $a_k = 0$.

By Proposition 1.7, the r -Eulerian polynomial is the hit polynomial for the board $B(r, 1; 1, 1; \dots, 1, 1; 1, r)$. (See Figure 1.4)

Definition 1.10. Suppose $M = \{1^{a_1}, \dots, k^{a_k}\}$ and $n = \#M = a_1 + \dots + a_k$. We define $B(M) = B_n(a_1, a_1; a_2, a_2; \dots; a_k, a_k)$.

Proposition 1.11. $E_M(x) = \frac{1}{a_1! \dots a_k!} H_n^{B(M)}(x)$.

Proof. Given $\sigma = \sigma_1 \dots \sigma_n \in S_n$, for each $i \in [1, n]$, there is a unique $j = j(i) \in [1, k]$ such that $\sigma_i \in [a_1 + \dots + a_{j-1} + 1, a_1 + \dots + a_j]$. Set $\Phi(\sigma) = j(1)j(2)\dots j(n) \in S_M$. The map Φ is $a_1! \dots a_k!$ to one, and $des_{B(M)}(\sigma) = des(\Phi(\sigma))$. We sum over all $\sigma \in S_n$ to obtain $H_n^{B(M)}(x) = a_1! \dots a_k! E_M(x)$. \square

In Savage and Visontai's paper [5], they defined the \mathbf{s} -Eulerian polynomials $E_n^{(\mathbf{s})}(x)$

for any sequence of positive integers $\mathbf{s} = (\tilde{s}_1, \tilde{s}_2, \dots)$. Let $J_n(\mathbf{s}) = [0, \tilde{s}_1 - 1] \times \dots \times [0, \tilde{s}_n - 1]$, and for any element $(e_1, \dots, e_n) \in J_n(\mathbf{s})$ (such an element is called an \mathbf{s} -inversion sequence), its ascent statistic is defined as $asc(e_1, \dots, e_n) = \{i \in [0, n - 1] \mid \frac{e_i}{\tilde{s}_i} < \frac{e_{i+1}}{\tilde{s}_{i+1}}\}$. In particular, $J_n(1, \dots, n)$ can be identified with S_n in such a way that asc corresponds to des ; namely, for $\sigma = \sigma_1 \dots \sigma_n \in S_n$, we associate with it $(e_1, \dots, e_n) \in J_n(1, \dots, n)$ where $e_i = \#\{j < i \text{ such that } \sigma_j > \sigma_i\}$. The \mathbf{s} -Eulerian polynomials are defined as $E_n^{(\mathbf{s})}(x) = \sum_{\mathbf{e} \in J_n(\mathbf{s})} x^{asc(\mathbf{e})}$, and they include the usual Eulerian polynomials as the $\mathbf{s} = (1, \dots, n)$ case. Savage and Visontai showed that many Eulerian-like polynomials are special cases of the \mathbf{s} -Eulerian polynomial.

Definition 1.12. We set $E_{n,i}^{(\mathbf{s})}(x) = \sum_{\substack{\mathbf{e} \in J_n(\mathbf{s}) \\ e_n = i}} x^{asc(\mathbf{s})}$, and let $\mathbf{E}_n^{(\mathbf{s})}$ be the row vector $[E_{n,0}^{(\mathbf{s})}(x), E_{n,1}^{(\mathbf{s})}(x), \dots, E_{n,\tilde{s}_n-1}^{(\mathbf{s})}(x)]$.

Theorem 1.13 (Lemma 2.1 in [5]). $\mathbf{E}_n^{(\mathbf{s})}(x) = \mathbf{E}_{n-1}^{(\mathbf{s})}(x)A(x)$, where $A = A(x)$ is the \tilde{s}_{n-1} -by- \tilde{s}_n matrix whose i th column starts with $\lceil \frac{(i-1)\tilde{s}_{n-1}}{\tilde{s}_n} \rceil$ copies of x from the top, and all 1's below them.

Definition 1.14. A $(1, x)$ -Ferrers matrix of shape B is a matrix whose entries are x and 1, and the x 's in which form the Ferrers board B in the top right corner. We also write (a, b) -Ferrers matrix, where the expressions a and b take the place of 1 and x respectively.

It is clear that the transition matrices $A(x)$ in Theorem 1.13 are all $(1, x)$ -Ferrers matrices.

Theorem 1.15. *Let A_1, A_2, \dots , be 1-by- m_1, m_1 -by- $m_2, \dots, (1, x)$ -Ferrers matrices. Then the sum of entries in the row vector $A_1 A_2 \dots A_n$ is a polynomial with only real roots.*

We will give a brief proof of Theorem 1.15 in Chapter 2 using results from [5] and [2]. In particular, when the transition matrices A_1, A_2, \dots have shapes as in Theorem 1.13, we obtain that the \mathbf{s} -Eulerian polynomials have only real roots. This is [5], Theorem 1.1.

The following two definitions are hit polynomial versions of Definition 1.12. In particular, Definition 1.17 reduces to the $\mathbf{s} = (1, 2, 3, \dots)$ case of Definition 1.12 when B is the upper triangular board. (See Remark 1.18)

Definition 1.16. For any Ferrers board B in the $n \times n$ array, let

$$H_{n,i}^B(x) = \sum_{\substack{C \in P_n \\ (i,n) \in C}} x^{h_B(C)}. \quad (1.11)$$

If c_n is the length of the longest column of B , we define

$$\mathbf{H}_n^B(x) = [H_{n,c_n+1}^B(x), \dots, H_{n,n}^B(x), H_{n,1}^B(x), \dots, H_{n,c_n}^B(x)]. \quad (1.12)$$

Definition 1.17. For any Ferrers board B in the $n \times n$ array, let

$$\tilde{H}_{n,j}^B(x) = \sum_{\substack{C \in P_n \\ (n,j) \in C}} x^{h_B(C)}, \quad (1.13)$$

and let $\tilde{\mathbf{H}}_n^B(x) = [\tilde{H}_{n,n}^B(x), \dots, \tilde{H}_{n,1}^B(x)]$.

Remark 1.18. The ϕ map before Theorem 1.6 satisfies the following:

- If i follows n in σ , then $\phi(\sigma)_i = n$.
- If $\sigma_n = i$, then $\phi(\sigma)_n = i$.

In view of Proposition 1.7, when B is contained in the triangular board, we have

$$\left\{ \begin{array}{l} H_{n,i}^B(x) = \sum_{\substack{\sigma \in S_n \\ i \text{ follows } n \text{ in } \sigma}} x^{\text{des}_B(\sigma)} \quad \text{for } i = 1, \dots, n-1 \\ H_{n,n}^B(x) = \sum_{\substack{\sigma \in S_n \\ \sigma_n = n}} x^{\text{des}_B(\sigma)} \\ \tilde{H}_{n,i}^B(x) = \sum_{\substack{\sigma \in S_n \\ \sigma_n = i}} x^{\text{des}_B(\sigma)} \quad \text{for } i = 1, \dots, n. \end{array} \right. \quad (1.14)$$

We will adopt the following shorthand throughout the paper:

Definition 1.19. For any Ferrers board $B = B_n(b_1, a_1; b_2, a_2; \dots; b_k, a_k)$, we set $s_i = a_1 + \dots + a_i$ and $t_i = b_1 + \dots + b_i$ for $i \in [0, k]$. In particular $s_0 = t_0 = 0$, $s_k = t_k = n$. The board of size $n-1$ we obtain from B by removing its last row and last column will be denoted B_0 .

The following two theorems mirror Theorem 1.13, and will be proved in Chapters 4 and 5 using a Ferrers equivalence argument. The transition matrices A and \tilde{A} are shown in Figure 1.5.

Theorem 1.20. *Suppose $B = B_n(b_1, a_1; b_2, a_2; \dots; b_k, a_k)$ is a Ferrers board with $b_k, a_k \geq 1$. If either*

$$b_k > 1 \text{ and } s_{i-1} \leq t_i - a_k + 1 \leq s_i \text{ for all } i \in [1, k-1];$$

or

$$b_k = 1 \text{ and } s_{i-1} \leq t_i - a_{k-1} - a_k + 1 \leq s_i \text{ for all } i \in [1, k-1],$$

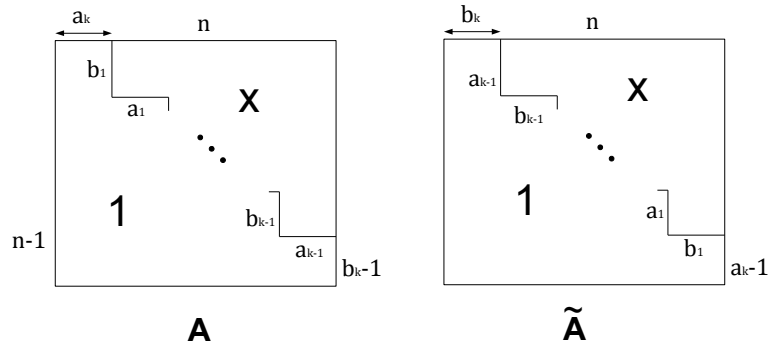

Figure 1.5: The $(n - 1)$ -by- n $(1, x)$ -Ferrers matrices A and \tilde{A} in Theorems 1.20 and 1.21, respectively. The shapes of the Ferrers boards in A and \tilde{A} are flipped versions of each other.

then $\mathbf{H}_n^B(x) = \mathbf{H}_{n-1}^{B_0}(x)A$, where A is the $(n - 1)$ -by- n $(1, x)$ -Ferrers matrix of shape $B(-, b_1; a_1, b_2; \dots; a_{k-2}, b_{k-1}; a_{k-1}, -)$.

Theorem 1.21. *Let B be the Ferrers board $B_n(b_1, a_1; \dots; b_k, a_k)$. Suppose either $b_k, a_k > 1$, or both $b_k = 1$ and $a_k \geq 1$. Suppose further that $t_{i-1} \leq s_{i-1} + a_k - 1 \leq t_i$ for all $i \in [1, k - 1]$. Then $\tilde{\mathbf{H}}_n^B = \tilde{\mathbf{H}}_{n-1}^{B_0}\tilde{A}$, where \tilde{A} is the $(n - 1)$ -by- n $(1, x)$ -Ferrers matrix with shape $B(-, a_{k-1}; b_{k-1}, a_{k-2}; \dots; b_2, a_1; b_1, -)$.*

There are versions of Theorems 1.20 and 1.21 for q -hit polynomials, and we will state and prove them in Chapters 4 and 5.

A Ferrers board B contained in the upper triangular board can be associated with the Dyck path forming its boundary (See Figure 1.6).

Proposition 1.22. *If B is contained in the upper triangular board, and when viewed as a Dyck path, B_0 has weakly decreasing peaks, and the heights of the valleys of B_0*

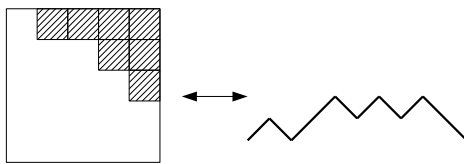

Figure 1.6: A board contained in the upper triangular board and its associated Dyck path.

(in order: v_1, \dots, v_l) satisfy $v_i \leq v_{i'} + 1$ for all $i < i'$, we can apply Theorem 1.20 (and its q -version Theorem 4.2) recursively and write $\mathbf{H}_n^B(x)$ as a product of $(1, x)$ -Ferrers matrices.

Proposition 1.23. *If B is contained in the upper triangular board, and when viewed as a Dyck path, B has weakly increasing valleys, and the heights of the peaks of B (in order: p_1, \dots, p_k) satisfy $p_i \geq p_{i'} - 1$ for all $i < i'$, we can apply Theorem 1.21 (and its q -version Theorem 5.2) recursively and write $\tilde{\mathbf{H}}_n^B(x)$ as a product of $(1, x)$ -Ferrers matrices.*

Boards that satisfy both Dyck path criteria in Propositions 1.22 and 1.23 include $B(r, 1; 1, 1; \dots; 1, r)$, the boards associated with the r -Eulerian polynomials, and $B(a_1, a_1; a_2, a_2; \dots; a_k, a_k)$ when $a_1 \geq \dots \geq a_k$, associated with the multiset Eulerian polynomials. We will look at these special cases in Chapter 6.

Chapter 2

Properties of interlacing polynomials

We will use material from Fisk's book [2] on interlacing polynomial. First we start with some notation:

Definition 2.1 ([2], Equation 1.1.1). For polynomials $f(x), g(x)$ with only real roots, let $a_1 \leq \dots \leq a_n$ be the roots of f , and $b_1 \leq \dots \leq b_m$ be the roots of g . We write

$$g \ll f \quad \text{if } m = n \quad \text{and } a_1 \leq b_1 \leq a_2 \leq b_2 \leq \dots \leq a_n \leq b_n$$

$$g \triangleleft f \quad \text{if } m = n + 1 \quad \text{and } b_1 \leq a_1 \leq b_2 \leq \dots \leq a_n \leq b_{n+1}.$$

We always list multiple roots that many times. Whenever we write $g \ll f$ or $g \triangleleft f$, we are assuming f and g have only real roots. The two relations \ll and \triangleleft are *interlacing* relations. We write $g \leftarrow f$ if $g \ll f$ or $g \triangleleft f$.

The following proposition from [2] gives us a way to locate the roots of a linear

combination of two interlacing polynomials, and will form the core of the proof of Theorem 1.5:

Proposition 2.2 ([2], Corollary 1.30). *Suppose $F \ll G$, both F and G are monic, and $\alpha, \beta, \alpha + \beta$ are non-zero. Let $H = \alpha F + \beta G$. Then*

$H \gg F$ if β and $\alpha + \beta$ have the same sign;

$H \ll F$ if β and $\alpha + \beta$ have opposite signs;

$H \ll G$ if α and $\alpha + \beta$ have the same sign; and

$H \gg G$ if α and $\alpha + \beta$ have opposite signs.

Suppose instead that $F \leq G$ (with no restriction on leading coefficients). Then $F \leftarrow H \leftarrow G$ if α and β have the same sign, and $F \rightarrow H \leftarrow G$ if they have opposite signs.

Remark 2.3. Since multiplying a polynomial by a constant does not alter its roots, the condition that both F and G are monic can be relaxed to that they have the same leading coefficient.

Corollary 2.4. *If $F \leftarrow G$, then $F \leftarrow F + G \leftarrow G$.*

A stronger form of interlacing can be defined for row vectors of polynomials.

Definition 2.5 (Compare [2] Def. 3.3). A row vector of polynomials in $\mathbb{R}[x]$ with positive coefficients, $\mathbf{v}(x) = [f_1(x), \dots, f_m(x)]$, is said to be *mutually interlacing* if $f_i \leftarrow f_j$ for all $i < j$. In other words, each f_i has only real roots (ordered $0 \geq \alpha_{i1} \geq \alpha_{i2} \geq \dots$), and the roots of all m polynomials are ordered as follows:

$$0 \geq \alpha_{m1} \geq \dots \geq \alpha_{11} \geq \alpha_{m2} \geq \dots \geq \alpha_{12} \geq \alpha_{m3} \geq \dots \geq \alpha_{13} \geq \dots$$

This sequence is cut off at some point, and all roots after that point are nonexistent.

Proposition 2.6. *If A is an m -by- n $(1, x)$ -Ferrers matrix and \mathbf{v} is a mutually interlacing row vector of length m , then $\mathbf{w}(x) := \mathbf{v}(x)A(x)$ is also a mutually interlacing row vector. In other words, $(1, x)$ -Ferrers matrices preserve mutual interlacing.*

Proof. A proof appears in Section 2 of [5], and the proof below is very similar to it. This is also a special case of [2], Proposition 3.72.

Suppose $\mathbf{v}(x) = [f_1(x), \dots, f_m(x)]$. For any $0 \leq k \leq l \leq m$, it suffices to show that

$$xF_1 + F_2 + F_3 \rightarrow xF_1 + xF_2 + F_3,$$

where $F_1 = f_1 + \dots + f_k$, $F_2 = f_{k+1} + \dots + f_l$, and $F_3 = f_{l+1} + \dots + f_m$. Repeated application of Corollary 2.4 gives us $f_1 \rightarrow F_1 \rightarrow f_k, f_{k+1} \rightarrow F_2 \rightarrow f_l$, and $f_{l+1} \rightarrow F_3 \rightarrow f_m$. Looking at the ordering of the roots, we find that $[F_1, F_2, F_3]$ is a mutually interlacing row vector. ²

Suppose the j th largest root of F_i is r_j^i for $i = 1, 2, 3$. Then we have

$$0 \geq r_1^3 \geq r_1^2 \geq r_1^1 \geq r_2^3 \geq \dots$$

Since $F_1 \rightarrow F_3$, we have $xF_1 \leftarrow F_3$. Let $\rho_1 \geq \rho_2 \geq \dots$ be the roots of $xF_1 + F_3$. By Corollary 2.4, we have

$$0 \geq \rho_1 \geq r_1^3 \geq r_1^2 \geq r_1^1 \geq \rho_2 \geq r_2^3 \geq \dots$$

²This assumes $0 < k < l < m$. The case $k = l$ is trivial; the cases $k = 0$ and/or $l = m$ must be dealt with separately, but the same argument works so we will omit them.

From here we see $F_2 \rightarrow xF_1 + F_3$ and $xF_2 \leftarrow xF_1 + F_3$. Let $\tilde{r}_1 \geq \tilde{r}_2 \geq \dots$ be the roots of $xF_1 + F_2 + F_3$, and $\tilde{r}'_1 \geq \tilde{r}'_2 \geq \dots$ be the roots of $xF_1 + xF_2 + F_3$. Two more applications of Corollary 2.4 yield

$$0 \geq \tilde{r}'_1 \geq \rho_1 \geq \tilde{r}_1 \geq r_1^2 \geq \tilde{r}'_2 \geq \rho_2 \geq \tilde{r}_2 \geq r_2^2 \geq \dots$$

Now it is clear that $xF_1 + F_2 + F_3 \rightarrow xF_1 + xF_2 + F_3$. □

Proposition 2.7 ([2], Lemma 3.5). *Let $\mathbf{v}(x) = [f_1(x), \dots, f_m(x)]$ be a mutually interlacing row vector. Then $f_1(x) + \dots + f_n(x)$ has only real roots. In fact, the same can be said for any nonnegative linear combination of f_1, \dots , and f_m , i.e. $c_1f_1(x) + \dots + c_mf_m(x)$ for any $c_i \geq 0$.*

Proof of Theorem 1.15. The first term A_1 is a 1-by- m_1 $(1, x)$ -Ferrers matrix, which is a mutually interlacing row vector. Since A_2, A_3, \dots are $(1, x)$ -Ferrers matrices, by Proposition 2.6 $A_1A_2\dots A_n$ is a mutually interlacing row vector. By Proposition 2.7, the sum of the entries in $A_1A_2\dots A_n$ is a polynomial with only real roots.

Chapter 3

Proof of Theorem 1.5

We will start with one of the recursions for $Q_B(x, q)$ in [3] that tells us how to add a column to B . They proved the following result by noting that the summand in the left-hand side of (1.7) vanishes for any $k < n - c_n$:

Proposition 3.1 (Lemma 2.7 in [3]). *Let $B = (c_1, \dots, c_n)$ be the Ferrers board with column lengths $0 \leq c_1 \leq \dots \leq c_n \leq n - 1$, and let $B_0 = (c_1, \dots, c_{n-1})$. Then*

$$\frac{Q_B(x, q)}{(1-x)\dots(1-xq^n)} = x^{n-c_n} \delta \left(\frac{x^{c_n-n+1} Q_{B_0}(x, q)}{(1-x)\dots(1-xq^{n-1})} \right), \quad (3.1)$$

where $\delta = \delta_q$ is the q -derivative operator:

$$\delta F(x) = \frac{F(qx) - F(x)}{qx - x}. \quad (3.2)$$

The q -derivative is linear and satisfies $\delta x^n = [n]x^{n-1}$. It also has a product rule:

Proposition 3.2. *For $u = u(x), v = v(x)$, we have $\delta(uv) = v\delta u + u(qx)\delta v$.*

Notation. In this chapter, we will often omit the q argument from polynomials.

We will sometimes omit x as well. Hence $Q_B = Q_B(x) = Q_B(x, q)$.

Suppose $q > 1$. Let B and B' be as in Lemma 3.1. Set $R(x, q) = x^{c_n - n + 1} Q_{B_0}(x, q)$ and $\tilde{R} = x^{c_n - n} Q_B$. We can then rewrite (3.1) as

$$\frac{\tilde{R}}{(1-x)\dots(1-xq^n)} = \delta \frac{R}{(1-x)\dots(1-xq^{n-1})}. \quad (3.3)$$

We can compute directly that

$$\delta \frac{1}{(1-x)\dots(1-xq^{n-1})} = \frac{[n]}{(1-x)\dots(1-xq^n)}. \quad (3.4)$$

Using Proposition 3.2 with $u = \frac{1}{(1-x)\dots(1-xq^{n-1})}$, $v = R$, we get

$$\delta \frac{R}{(1-x)\dots(1-xq^{n-1})} = \frac{(1-x)\delta R + [n]R}{(1-x)\dots(1-xq^n)}. \quad (3.5)$$

Hence

$$\tilde{R} = [n]R - (x-1)\delta R. \quad (3.6)$$

Lemma 3.3. *Let B be as in Proposition 3.1, and R and \tilde{R} be as above. Suppose $R(qx) \ll R(x)$. Then $\tilde{R}(qx) \ll \tilde{R}(x)$. Equivalently, suppose $Q_{B_0}(qx) \ll Q_{B_0}(x)$; then $Q_B(qx) \ll Q_B(x)$.*

Proof. Let $m = \deg_x(R)$. If $m = 0$, then $\tilde{R} = [n]R$; neither R or \tilde{R} has any root and the Lemma holds. Hence we may assume $m > 0$.

Suppose the roots of R are $r_m \leq r_{m-1} \leq \dots \leq r_1$. Then $R(qx) \ll R(x)$ implies

$$r_m \leq \frac{r_m}{q} \leq \dots \leq r_1 \leq \frac{r_1}{q}.$$

Since $q > 1$, $r_1 \leq \frac{r_1}{q}$ implies $r_1 \leq 0$. By definition of δ ,

$$x(q-1)\delta R = R(qx) - R(x). \quad (3.7)$$

We apply Proposition 2.2 with $G = R, F = \frac{R(qx)}{q^m}, \beta = -1, \alpha = q^m$ and obtain $x\delta R \ll R$ and $x\delta R \ll R(qx)$. (This is [2], Theorem 8.8)

Suppose the roots of δR are $\rho_{m-1} \leq \dots \leq \rho_1$. Then the roots of $R, R(qx)$, and δR (all negative) are ordered weakly from smallest to largest as follows.

$$r_m, \frac{r_m}{q}, \rho_{m-1}, r_{m-1}, \frac{r_{m-1}}{q}, \dots, \rho_2, r_2, \frac{r_2}{q}, \rho_1, r_1, \frac{r_1}{q}$$

In particular, we see that $(x-1)\delta R \ll R$.

Let ax^m be the leading term of \tilde{R} . Then $a[m]x^m$ is the leading term of $(x-1)\delta R$.

We apply Proposition 2.2 to (3.6) with $F = \frac{(x-1)\delta R}{[m]}, G = R, \alpha = -[m], \beta = [n]$ and obtain $R \ll \tilde{R}$ and $(x-1)\delta R \ll \tilde{R}$.³ Let $\tilde{r}_m \leq \dots \leq \tilde{r}_1$ be the roots of \tilde{R} . These roots fit into the picture as follows:

$$\tilde{r}_m, r_m, \frac{r_m}{q}, \rho_{m-1}, \tilde{r}_{m-1}, r_{m-1}, \frac{r_{m-1}}{q}, \dots, \rho_2, \tilde{r}_2, r_2, \frac{r_2}{q}, \rho_1, \tilde{r}_1, r_1, \frac{r_1}{q}$$

We have $\tilde{r}_{i+1} \leq r_{i+1} \leq \frac{r_{i+1}}{q} \leq \tilde{r}_i \leq 0$ for $i = 1, \dots, m-1$. This implies $\tilde{r}_{i+1} \leq \frac{\tilde{r}_{i+1}}{q} \leq \tilde{r}_i \leq 0$, and hence $\tilde{R}(qx) \ll \tilde{R}(x)$. This proof is inspired by Chapter 8 of [2] (and the first half of this proof appears in it), where the set of polynomials f satisfying $f(x) \ll f(qx)$ and the q -derivative are studied. \square

³Here $m < n$ because $m = \deg(R) \leq \deg(Q_{B_0}) \leq n-1$.

Proposition 3.4. Fix $q > 1$. For any Ferrers board B , we have $Q_B(qx) \ll Q_B(x)$.

Both $Q_B(x, q)$ and $H_n^B(x, q)$ have only real roots.

Proof. The proof is by induction. If the board is empty in an n -by- n array, then Q_B is a constant times x^n , and the assertions are true. Given a Ferrers board B in n -by- n array, we suppose that for all boards B' in an array smaller than n -by- n , and for all boards B' in the n -by- n array with less cells than B , we have $Q_{B'}(qx) \ll Q_{B'}(x)$. Let $B = (c_1, \dots, c_n)$. If $c_n \leq n - 1$, let $B' = B_0 = (c_1, \dots, c_{n-1})$. By Lemma 3.3 and the induction hypothesis, we obtain $Q_B(qx) \ll Q_B(x)$. If $c_n = n$, set $B' = (0, c_1, \dots, c_{n-1})$. Since $Q_B = \frac{1}{x}Q_{B'}$ (we can get this from Lemmas 2.1 and 2.3 in [3]), the induction hypothesis implies $Q_B(qx) \ll Q_B(x)$.

We have proved $Q_B(qx) \ll Q_B(x)$, and in particular $Q_B(x)$ has only real roots. Since $H_n^B(x) = x^n Q_B(x^{-1})$, the nonzero roots of H_n^B and Q_B are inverses of each other. Hence H_n^B also has only real roots. \square

Now suppose $0 < q < 1$. We start with (3.3), but this time we apply Proposition 3.2 with $u = R, v = \frac{1}{(1-x)\dots(1-xq^{n-1})}$. We get

$$\tilde{R} = [n]R(qx) - (q^n x - 1)\delta R. \tag{3.8}$$

Lemma 3.5. If $R(qx) \gg R(x)$. Then $\tilde{R}(qx) \gg \tilde{R}(x)$

Proof. Let $m = \deg(R)$. As in the $q > 1$ case, we may assume $m > 0$. Suppose the roots of R are $r_m \leq r_{m-1} \leq \dots \leq r_1$. Then $R(qx) \gg R(x)$ implies

$$\frac{r_m}{q} \leq r_m \leq \dots \leq \frac{r_1}{q} \leq r_1.$$

Since $q < 1$, $\frac{r_1}{q} \leq r_1$ implies $r_1 \leq 0$. We apply Proposition 2.2 to (3.7) with $F = R, G = \frac{R(qx)}{q^m}, \alpha = -1, \beta = q^m$ and obtain $x\delta R \ll R$ and $x\delta R \ll R(qx)$.

Let $\rho_{m-1} \leq \dots \leq \rho_1$ be the roots of δR . Then the roots of $R, R(qx)$, and $(1-xq^n)\delta R$ (all negative) are as follows, from smallest to largest:

$$\frac{r_m}{q}, r_m, \rho_{m-1}, \dots, \rho_2, \frac{r_2}{q}, r_2, \rho_1, \frac{r_1}{q}, r_1$$

In particular $(q^n x - 1)\delta R \ll R(qx)$. If R has leading term ax^m , then $R(qx)$ has leading term $aq^m x^m$ and $(q^n x - 1)\delta R$ has leading term $aq^n [m]x^m$. Therefore $R(qx)$ and $\frac{q^{m-n}}{[m]}(q^n x - 1)\delta R$ have the same leading coefficient. We apply Proposition 2.2 to (3.8) with $G = R(qx), F = \frac{q^{m-n}}{[m]}(q^n x - 1)\delta R, \beta = [n], \alpha = -[m]q^{n-m} = [n - m] - [n]$ and obtain $\tilde{R} \gg (q^n x - 1)\delta R$ and $\tilde{R} \gg R(qx)$. Let $\tilde{r}_1 \leq \dots \leq \tilde{r}_m$ be the roots of \tilde{R} .

We then have

$$\tilde{r}_m, \frac{r_m}{q}, r_m, \rho_{m-1}, \tilde{r}_{m-1}, \dots, \rho_2, \tilde{r}_2, \frac{r_2}{q}, r_2, \rho_1, \tilde{r}_1, \frac{r_1}{q}, r_1$$

In particular $\tilde{r}_{i+1} \leq \frac{r_{i+1}}{q} \leq r_{i+1} \leq \tilde{r}_i$ for $i = 1, \dots, m - 1$. Hence $\tilde{r}_{i+1} \leq \frac{\tilde{r}_i}{q} \leq \tilde{r}_i$ and so $\tilde{R}(qx) \gg \tilde{R}(x)$. \square

The rest of the argument is identical to the $q > 1$ case, except that \ll is replaced with \gg . We get

Proposition 3.6. *Fix $0 < q < 1$. For any Ferrers board B , we have $Q_B(qx) \gg Q_B(x)$. Both Q_B and H_n^B have only real roots.*

Combine Propositions 3.4 and 3.6 and we have proved Theorem 1.5. As stated in the introduction, the $q = 1$ case was known; we can also obtain the $q = 1$ case from

the $q > 1$ case using that limits of real-rooted polynomials have only real roots ([2], Lemma 1.40).

When B is the upper triangular board $(0, 1, \dots, n - 1)$, we have $Q_B(x, q) = \sum_{\sigma \in S_n} x^{\text{des}(\sigma)+1} q^{\text{maj}(\sigma)}$, the *MacMahon-Carlitz q -Eulerian polynomials*. To obtain this, we can combine Equations I.2, I.9, I.10, and I.12 from [3]. It was shown in [5], Theorem 5.4 that the q -Eulerian polynomials have only real roots for $q > 0$.

Chapter 4

Proof of Theorem 1.20

In Dworkin's paper [1], they found an explicit statistic ξ_B defined on P_n , and showed that $H_n^B(x, q) = \sum_{C \in P_n} x^{h_B(C)} q^{\xi_B(C)}$, which is a refinement of (1.1). Here B is any *skyline board* B , which is obtained from a Ferrers board via a permutation on the columns. Given a placement $C \in P_n$, we compute $\xi_B(C)$ as follows. We say a cell is canceled if either there is a rook on it, or it is to the right of a rook. Put a circle on any uncanceled cell on B below a rook (on B); on any uncanceled cell on B above a rook off B ; and on any uncanceled cell off B below a rook off B . We define $\xi_B(\sigma)$ to be the number of circles we get this way. See Figure 4.1 for an example.

Definition 4.1. Let $H_{n,i}^B(x, q) = \sum_{\substack{C \in P_n \\ (i,n) \in C}} x^{h_B(C)} q^{\xi_B(C)}$. We define $\mathbf{H}_n^B(x, q)$ the same way we defined $H_n^B(x)$ in Definition 1.16.

We will prove the following q -version of Theorem 1.20 in this chapter:

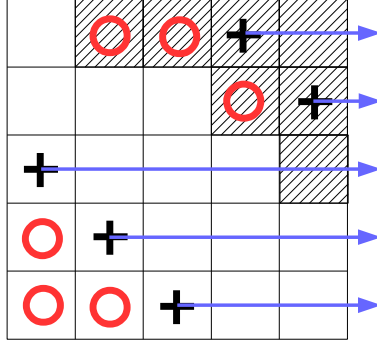

Figure 4.1: Computation of ξ_B . Here $\xi_B(\sigma) = 6$.

Theorem 4.2. *Let B be as in Theorem 1.20, and let s_i , t_i and B_0 be as in Definition 1.19. Then*

$$\mathbf{H}_n^B(x, q) = \mathbf{H}_{n-1}^{B_0}\left(\frac{x}{q}, q\right) A\left(\frac{x}{q}\right) D, \quad (4.1)$$

where $A\left(\frac{x}{q}\right)$ is the $(n-1)$ -by- n $\left(1, \frac{x}{q}\right)$ -Ferrers matrix of shape

$$B(-, b_1; a_1, b_2; a_2, b_3; \dots; a_{k-1}, -),$$

and D is the diagonal matrix with $q^{s_{k-1}}, \dots, q^{n-1}, q^{-t_1+n}, \dots, q^{-t_1+s_1+n-1},$

$q^{-t_2+s_1+n}, \dots, q^{-t_2+s_2+n-1}, \dots, q^{-t_{k-1}+s_{k-2}+n}, \dots, q^{-t_{k-1}+s_{k-1}+n-1}$ down the diagonal.

Let $I_0 = [s_{k-1} + 1, n]$, and let $I_i = [s_{i-1} + 1, s_i]$ for $i \in [1, k-1]$.

Definition 4.3. For $i \in [1, k-1]$, let

$$B_i = B_{n-1}(b_1, a_1; \dots; b_{i-1}, a_{i-1}; b_i, a_i - 1; b_{i+1}, a_{i+1}; \dots; b_{k-1}, a_{k-1}; b_k - 1, a_k)$$

be the board we obtain by removing the j th row and the n th column from B for any $j \in I_i$. Let B^i be the board obtained by removing the leftmost cell from each of the

bottommost $n - 1 - t_i$ rows of the board B_0 . See Figure 4.2 for the board B^i when $b_k > 1$ and $s_{i-1} \leq t_i - a_k + 1 \leq s_i$.

Lemma 4.4. *If B satisfies the conditions in Theorem 1.20, then B_i and B^i are Ferrers equivalent for $i = 1, \dots, k - 1$.*

Proof. We will combine equal column lengths and write, for example, (3^5) for five consecutive columns of length 3.

The column lengths of B_i are $(c_1, \dots, c_{n-1}) =$

$$(0^{b_1}, s_1^{b_2}, s_2^{b_3}, \dots, s_{i-1}^{b_i}, (s_i - 1)^{b_{i+1}}, (s_{i+1} - 1)^{b_{i+2}}, \dots, (s_{k-2} - 1)^{b_{k-1}}, (s_{k-1} - 1)^{b_k}).$$

Suppose $b_k > 1$ and $s_{i-1} \leq t_i - a_k + 1 \leq s_i$. From Figure 4.2, the column lengths of B^i are $(c'_1, \dots, c'_{n-1}) :=$

$$(0^{b_1}, s_1^{b_2}, s_2^{b_3}, \dots, s_{i-1}^{b_i}, t_i - a_k + 1, s_i^{b_{i+1}}, s_{i+1}^{b_{i+2}}, \dots, s_{k-2}^{b_{k-1}}, s_{k-1}^{b_k}).$$

Comparing the two sequences, we see that

$$\begin{cases} c_l - l + 1 = c'_l - l + 1 & \text{for } l \in [1, t_i] \\ c_l - l + 1 = c'_{l+1} - (l + 1) + 1 & \text{for } l \in [t_i + 1, n - 2]. \end{cases} \quad (4.2)$$

Finally,

$$c_{n-1} - (n - 1) + 1 = -a_k = t_i - a_k + 1 - (t_i + 1) + 1 = c'_{t_i+1} - (t_i + 1) + 1.$$

Hence the multisets $\{c_i - i + 1\}_{i=1, \dots, n-1}$ and $\{c'_i - i + 1\}_{i=1, \dots, n-1}$ are the same, and so

B_i and B^i are Ferrers equivalent.

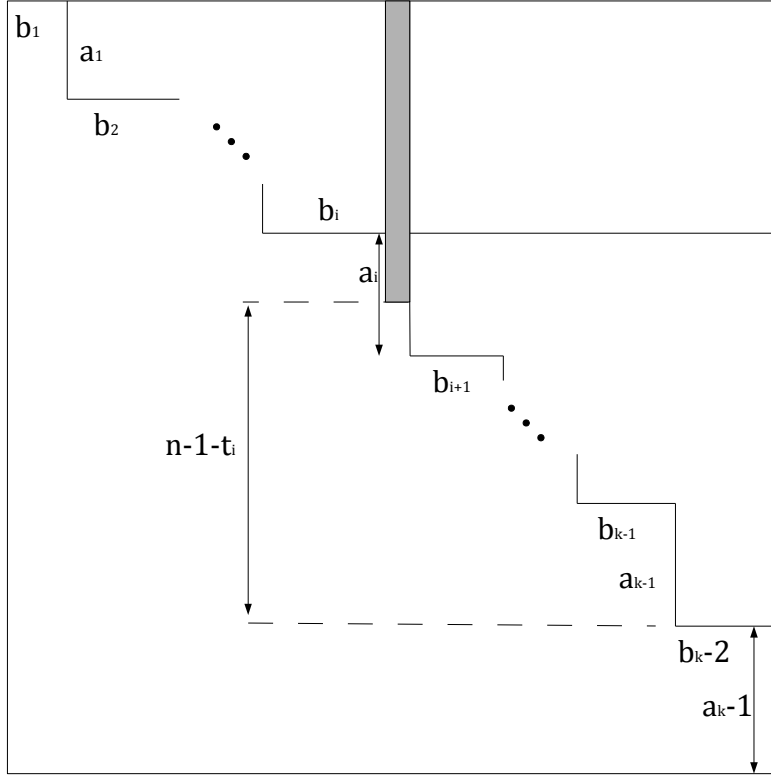

Figure 4.2: The board B^i in the $b_k > 1$ case. The condition $s_{i-1} \leq t_i - a_k + 1 \leq s_i$ is necessary for this to be an accurate depiction of B^i , namely the odd column (in gray) appears between the two horizontal segments of lengths b_i and b_{i+1} . To obtain \bar{B}^i from B^i , we permute the columns of B^i so the gray column becomes the last column, with the ordering of all other columns unchanged.

On the other hand, suppose $b_k = 1$ and $s_{i-1} \leq t_i - a_{k-1} + a_k + 1 \leq s_i$. The column lengths of B^i are now

$$(0^{b_1}, s_1^{b_2}, s_2^{b_3}, \dots, s_{i-1}^{b_i}, t_i - a_{k-1} - a_k + 1, s_i^{b_{i+1}}, s_{i+1}^{b_{i+2}}, \dots, s_{k-2}^{b_{k-1}-1}).$$

One can check similarly that this gives the same multiset as the one for B^i .

□

Let $i \in [0, k-1]$ and $j \in I_i$. Let $P_{n,j} \subset P_n$ be the subset of placements that have a rook at (j, n) . There is a bijection between $\tilde{C} \in P_{n,j}$ and $C \in P_{n-1}$ simply via removing the j th row and the n th column from \tilde{C} .

Lemma 4.5. *With $j \in I_i$ and C, \tilde{C} as above, we have*

$$\begin{cases} h_B(\tilde{C}) = h_{B_0}(C) & \text{for } i = 0 \\ h_B(\tilde{C}) = h_{B_i}(C) + 1 & \text{for } i \in [1, k-1] \end{cases} \quad (4.3)$$

and

$$\begin{cases} \xi_B(\tilde{C}) = \xi_{B_0}(C) + j - 1 - h_{B_0}(C) & \text{for } i = 0 \\ \xi_B(\tilde{C}) = \xi_{B_i}(C) - t_i + j - 1 + n - 1 - h_{B_i}(C) & \text{for } i \in [1, k-1] \end{cases} \quad (4.4)$$

In other words,

$$\begin{cases} H_{n,j}^B(x, q) = q^{j-1} H_{n-1}^{B_0}(\frac{x}{q}, q) & \text{for } j \in I_0 \\ H_{n,j}^B(x, q) = xq^{-t_i+j-1+n-1} H_{n-1}^{B_i}(\frac{x}{q}, q) & \text{for } j \in I_i, i \in [1, k-1] \end{cases} \quad (4.5)$$

Proof. The first part is clear, since $h_B(\tilde{C}) = h_{B_i}(C) + 1$ if (j, n) is on B , otherwise $h_B(\tilde{C}) = h_{B_i}(C)$.

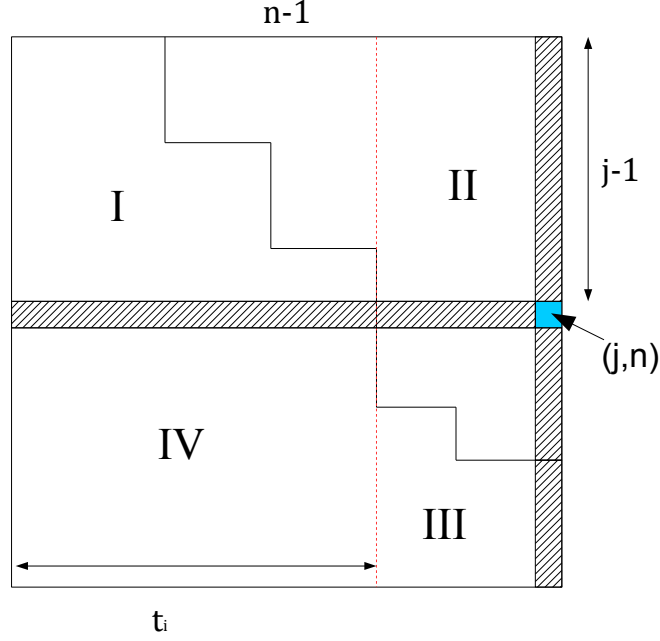

Figure 4.3: Regions I, II, III and IV. The vertical line that separates I from II, and III from IV, contains the vertical segment of the boundary of B inside the j th row. Regions I and III lie outside the board B .

Now we look at ξ . We assume $i \in [1, k - 1]$ for now. Define the regions I, II, III, IV as in Figure 4.3. We also define I' as the rectangular region that is above the j th row and to the left of II.

The contribution to $\xi_B(\tilde{C})$ outside the j th row and the n th column is exactly $\xi_{B_i}(C)$. Furthermore, the n th column contributes nothing to $\xi_B(\tilde{C})$, since all cells on that column get canceled when we compute ξ_B . Hence $\xi_B(\tilde{C}) = \xi_{B_i}(C) +$ number of circles on the j th row.

By definition of ξ , the number of circles on the j th row = $\#I + \#II + \#III$, here

we abbreviate the number of rooks of \tilde{C} in I as $\#I$, and so on. But since each row and column has exactly one rook, we have $\#II = j - 1 - \#I = j - 1 - (t_i - \#IV) = \#IV - t_i + j - 1$. Hence

$$\begin{aligned} \text{the number of circles on } j\text{th row} &= \#I + \#III + \#IV - t_i + j - 1 \\ &= n - 1 - h_{B_i}(C) - t_i + j - 1. \end{aligned} \quad (4.6)$$

Hence $\xi_B(\tilde{C}) = \xi_{B_i}(C) - t_i + j - 1 + n - 1 - h_{B_i}(C)$.

Now suppose instead $i = 0$. The regions II and III disappear. Now the number of circles on the j th row $= \#I = j - 1 - h_{B_0}(C)$. Hence $\xi_B(\tilde{C}) = \xi_{B_0}(C) + j - 1 - h_{B_0}(C)$. \square

For $i \in [1, k - 1]$, let \bar{B}^i be the skyline board obtained from B_0 by removing the bottommost $n - 1 - t_i$ cells from the rightmost (i.e. $(n - 1)$ th) column. Since B^i and \bar{B}^i differ by a column permutation (See description under Figure 4.2), B_i, B^i and \bar{B}^i are all equivalent boards. By Corollary 1.4, we have $H_{n-1}^{B_i}(x, q) = H_{n-1}^{\bar{B}^i}(x, q)$.

Hence (4.5) can be rewritten as

$$\begin{cases} H_{n,j}^B(x, q) = q^{j-1} H_{n-1}^{B_0}(\frac{x}{q}, q) & \text{for } j \in I_0 \\ H_{n,j}^B(x, q) = xq^{-t_i+j-1+n-1} H_{n-1}^{\bar{B}^i}(\frac{x}{q}, q) & \text{for } j \in I_i, i \in [1, k-1] \end{cases} \quad (4.7)$$

We still need to express $H_{n-1}^{\bar{B}^i}(x, q)$ in terms of $H_{n-1,l}^{B_0}(x, q)$. To combine the $b_k > 1$ and $b_k = 1$ cases, let $c = c_{n-1}(B_0)$ = the length of the longest column of B_0 . In other words, $c = s_{k-1}$ if $b_k > 1$, and $c = s_{k-2}$ if $b_k = 1$.

Lemma 4.6. *For $i \in [1, k - 1]$, we have $H_{n-1}^{\bar{B}^i}(x, q)$*

$$= \sum_{l=c+1}^{n-1} H_{n-1,l}^{B_0}(x, q) + \sum_{l=1}^{c-(n-1-t_i)} H_{n-1,l}^{B_0}(x, q) + \frac{1}{x} \left[\sum_{l=c-(n-1-t_i)+1}^c H_{n-1,l}^{B_0}(x, q) \right]$$

Proof. Since we get \bar{B}^i by removing the cells $\{(l, n-1)\}_{l \in [c-(n-1-t_i)+1, c]}$ from B_0 , we have for any $C \in P_{n-1}$ such that $(l, n-1) \in C$,

$$\begin{cases} h_{B_0}(C) = h_{\bar{B}^i}(C) + 1 & \text{if } l \in [c - (n-1-t_i) + 1, c] \\ h_{B_0}(C) = h_{\bar{B}^i}(C) & \text{otherwise.} \end{cases} \quad (4.8)$$

Also, $\xi_{B_0}(C) = \xi_{\bar{B}^i}(C)$ for all C . This implies

$$H_{n-1, l}^{\bar{B}^i}(x, q) = \begin{cases} \frac{1}{x} H_{n-1, l}^{B_0}(x, q) & \text{for } l \in [c - (n-1-t_i) + 1, c] \\ H_{n-1, l}^{B_0}(x, q) & \text{for } l \in [c+1, n-1] \text{ or } l \in [1, c - (n-1-t_i)] \end{cases} \quad (4.9)$$

The lemma then follows from $H_{n-1}^{\bar{B}^i}(x, q) = \sum_{l=1}^{n-1} H_{n-1, l}^{\bar{B}^i}$. \square

It follows from (4.7) and Lemma 4.6 that

$$\begin{cases} H_{n, j}^B(x) = q^{j-1} \left[\sum_{l=c+1}^{n-1} H_{n-1, l}^{B_0}\left(\frac{x}{q}\right) + \sum_{l=1}^c H_{n-1, l}^{B_0}\left(\frac{x}{q}\right) \right] & \text{for } j \in I_0 \\ H_{n, j}^B(x) = q^{-t_i+j+n-1} \left[\frac{x}{q} \left[\sum_{l=c+1}^{n-1} H_{n-1, l}^{B_0}\left(\frac{x}{q}\right) + \sum_{l=1}^{c-(n-1-t_i)} H_{n-1, l}^{B_0}\left(\frac{x}{q}\right) \right] \right. \\ \quad \left. + \sum_{l=c-(n-1-t_i)+1}^c H_{n-1, l}^{B_0}\left(\frac{x}{q}\right) \right] & \text{for } j \in I_i, i \in [1, k-1] \end{cases} \quad (4.10)$$

This describes a recurrence relation between $\mathbf{H}_n^B(x, q)$ and $\mathbf{H}_{n-1}^{B_0}\left(\frac{x}{q}, q\right)$, which can be written in the form of a matrix. Referring back to the definition of these row vectors (Definition 1.16), we see that $\mathbf{H}_n^B(x, q) = \mathbf{H}_{n-1}^{B_0}\left(\frac{x}{q}, q\right) A\left(\frac{x}{q}\right) D$, where the diagonal matrix D collects the powers q^{j-1} and $q^{-t_i+j+n-1}$. It can then be checked that the matrices $A\left(\frac{x}{q}\right)$ and D are as stated in Theorem 4.2.

A *subboard* of B is the first m rows and m columns of B , considered as a board in the m -by- m array, for some $m < n$. To apply Theorem 4.2 recursively to a board

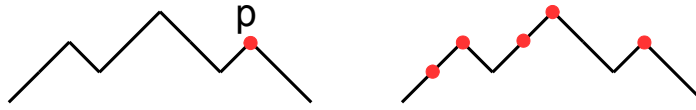

Figure 4.4: Left: the Dyck path B_0 and its last peak p . Right: the set of all last peaks as we progressively truncate B_0 .

B , we need all the subboards of B to satisfy the conditions in Theorem 1.20 if the subboard were to replace B .

Suppose B is contained in the upper triangular board. Note that the last peak of B_0 as a Dyck path is at height $a_k - 1$ if $b_k > 1$, and height $a_{k+1} + a_k - 1$ if $b_k = 1$. The inequalities $t_i - s_{i-1} \geq a_k - 1$ and $t_i - s_i \leq a_k - 1$ mean that each peak (of B_0) is at least as high as the last peak, and each valley is at most as high as the last peak, respectively. When we look at a subboard B' of B , we truncate the Dyck path, and the corresponding last peak of $(B')_0$ moves to the left as we progressively look at smaller subboards. See Figure 4.4 for all the last peaks we get this way, marked as red dots. The Dyck path criterion in Proposition 1.22 is the same as saying that every peak of B_0 is at least as high as any red dot to the right of it, and every valley of B_0 is at most as high as any red dot to the right of it. In this case we can express $\mathbf{H}_n^B(x, q)$ as a matrix product by applying Theorem 4.2 recursively.

Chapter 5

Proof of Theorem 1.21

We define a flipped version of Dworkin's ξ statistic, denoted $\tilde{\xi}$, for any board B that can be obtained from a Ferrers board via a permutation on the rows (a *row-skyline board*). See Figure 5.1 for the computation of $\tilde{\xi}$; it is simply Figure 4.1 flipped across the anti-diagonal. Since the transpose of a Ferrers board is equivalent to the board

itself, we have $H_n^B(x, q) = \sum_{C \in P_n} x^{h_B(C)} q^{\tilde{\xi}_B(C)}$.⁴

Definition 5.1. Let $\tilde{H}_{n,i}^B(x, q) = \sum_{\substack{C \in P_n \\ (i,n) \in C}} x^{h_B(C)} q^{\tilde{\xi}_B(C)}$. We define $\tilde{\mathbf{H}}_n^B(x, q)$ similar to how we defined $\tilde{\mathbf{H}}_n^B(x)$ in Definition 1.17.

Theorem 5.2. *Let B be the Ferrers board $B_n(b_1, a_1; \dots; b_k, a_k)$, and let s_i, t_i , and B_0 be as in Definition 1.19. Suppose either $b_k, a_k > 1$, or both $b_k = 1$ and $a_k \geq 1$.*

⁴In this chapter, we will take this as the definition of $H_n^B(x, q)$. This is different from the definition of $H_n^B(x, q)$ in Chapter 4 for skyline boards, but the two definitions coincide when B is a Ferrers board.

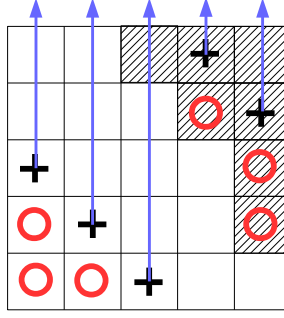

Figure 5.1: The computation of $\tilde{\xi}$.

Suppose further that $t_{i-1} \leq s_{i-1} + a_k - 1 \leq t_i$ for all $i \in [1, k-1]$. Then

$$\tilde{\mathbf{H}}_n^B(x, q) = \tilde{\mathbf{H}}_{n-1}^{B_0} \tilde{A} D, \quad (5.1)$$

where \tilde{A} is the $(n-1)$ -by- n (q^{n-1-a_k}, xq^{-a_k}) -Ferrers matrix with shape

$$B(-, a_{k-1}; b_{k-1}, a_{k-2}; \dots; b_2, a_1; b_1, -),$$

and D is the n -by- n diagonal matrix with

$$(q^{t_k - s_{k-1}}, \dots, q^{t_{k-1} + 1 - s_{k-1}}; q^{t_{k-1} - s_{k-2}}, \dots, q^{t_{k-2} + 1 - s_{k-2}}; \dots; q^{t_1}, \dots, q^1)$$

down the diagonal.

Let B' is B with the j th column and n th row removed. For $C \in P_n, (n, j) \in C$, let $C' \in P_{n-1}$ be C with the j th column and n th row removed. Since $a_k \geq 1$, the board B does not reach the n th row. Hence $h_B(C) = h_{B'}(C')$. When we compute $\tilde{\xi}_B(C)$, the entire j th column is canceled, and on the n th row there is a circle in every cell to the left of (n, j) , and no circle to the right of (n, j) . Hence $\tilde{\xi}_B(C) = \tilde{\xi}_{B'}(C') + j - 1$,

which implies

$$\begin{aligned}
\tilde{H}_{n,j}^B(x, q) &= \sum_{\substack{C \in P_n \\ (n,j) \in C}} x^{h_B(C)} q^{\tilde{\xi}_B(C)} \\
&= q^{j-1} \sum_{C' \in P_{n-1}} x^{h_{B'}(C')} q^{\tilde{\xi}_{B'}(C')} \\
&= q^{j-1} H_{n-1}^{B'}(x, q)
\end{aligned} \tag{5.2}$$

Suppose $j \in \tilde{I}_i$, where $\tilde{I}_i = [t_{i-1} + 1, t_i]$ for $i = 1, \dots, k$. The board B' is Ferrers equivalent to the board

$$\begin{aligned}
B^* &= B_{n-1}(b_1, a_1; \dots; b_{i-1}, a_{i-1}; s_{i-1} + a_k - t_{i-1} - 1, 1; t_i - s_{i-1} - a_k + 1, a_i; \\
&\quad b_{i+1}, a_{i+1}; \dots; b_{k-1}, a_{k-1}; b_k - 1, a_k - 2);
\end{aligned}$$

see Figure 5.2. (In the $b_k = 1, a_k \geq 1$ case, B^* ends in $\dots; b_{k-1}, a_{k-1} + a_k - 2$ instead.)

If $b_k, a_k > 1$, then $B_0 = B_{n-1}(b_1, a_1; \dots; b_k - 1, a_k - 1)$. If $b_k = 1$ and $a_k \geq 1$, then $B_0 = B_{n-1}(b_1, a_1; \dots; b_{k-2}, a_{k-2}; b_{k-1}, a_{k-1} + a_k - 1)$. In both cases, The board B^* is equivalent to $B'' = B_0 \cup \{(n-1, s_{i-1} + a_k), \dots, (n-1, n-1)\}$ through a permutation on the rows.

Lemma 5.3. *Let $C \in P_{n-1}$, $(n-1, l) \in C$. Then if $l \geq s_{i-1} + a_k$, then*

$$\begin{cases} h_{B''}(C) = h_{B_0}(C) + 1 \\ \tilde{\xi}_{B''}(C) = \tilde{\xi}_{B_0}(C) + 1 - a_k - s_{i-1} \end{cases} \tag{5.3}$$

On the other hand if $l < s_{i-1} + a_k$, then

$$\begin{cases} h_{B''}(C) = h_{B_0}(C) \\ \tilde{\xi}_{B''}(C) = \tilde{\xi}_{B_0}(C) + n - a_k - s_{i-1}. \end{cases} \tag{5.4}$$

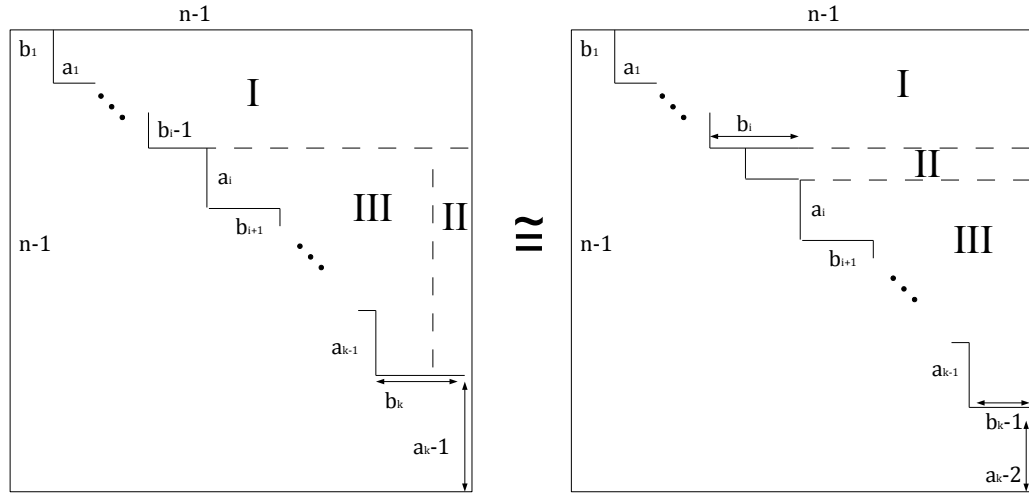

Figure 5.2: The equivalent Ferrers boards B' and B^* . If we divide B' (shown on the left) into three regions as shown, where region II is within a single column, we can obtain the other board by moving these three pieces around: namely region I does not move at all, region III moves one step down and one step to the right, and region II becomes a row of the same length and is placed between the two. The resulting board B^* (shown on the right) is a Ferrers board iff the length of region II lies weakly between the length of the top row of region III and the length of the bottom row of region I. This condition simplifies to $t_{i-1} \leq s_{i-1} + a_k - 1 \leq t_i$. To obtain B'' from B^* , move region II all the way down to the $(n-1)$ th row, and shift region III up one step. Regions I and III combined in this way is the board B_0 .

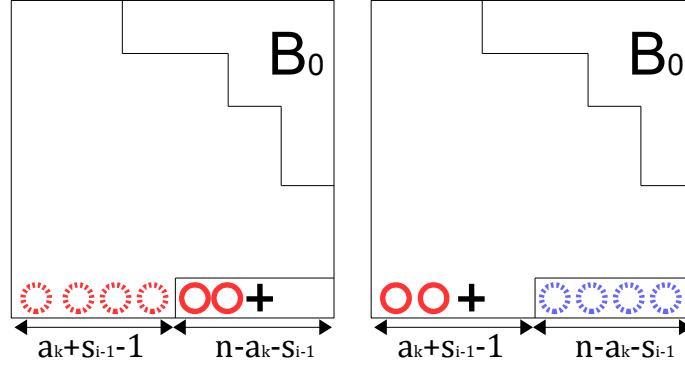

Figure 5.3: Comparison of $\tilde{\xi}_{B''}$ and $\tilde{\xi}_{B_0}$.

Proof. See Figure 5.3. The plus sign is the rook at $(n-1, l)$. If $l \geq s_{i-1} + a_k$ (shown on the left), the circles in dotted red at $(n-1, 1), \dots, (n-1, a_k + s_{i-1} - 1)$ contribute to $\tilde{\xi}_{B_0}(C)$ but not $\tilde{\xi}_{B''}(C)$. If $j < s_{i-1} + a_k$ (shown on the right), the circles in dotted blue at $(n-1, a_k + s_{k-1}), \dots, (n-1, a_k + s_{i-1} - 1)$ contribute to $\tilde{\xi}_{B''}(C)$ but not $\tilde{\xi}_{B_0}(C)$. \square

This implies

$$H_{n-1}^{B''} = xq^{1-a_k-s_{i-1}} \left[\sum_{l=s_{i-1}+a_k}^{n-1} \tilde{H}_{n-1,l}^{B_0} \right] + q^{n-a_k-s_{i-1}} \left[\sum_{l=1}^{s_{i-1}+a_k-1} \tilde{H}_{n-1,l}^{B_0} \right]. \quad (5.5)$$

Combining (5.2), (5.5), and the fact that B' and B'' have the same q -hit polynomials, we get for any $i \in [1, k]$ and $j \in I_i$,

$$\begin{aligned} \tilde{H}_{n,j}^B(x, q) &= xq^{j-a_k-s_{i-1}} [\tilde{H}_{n-1,n-1}^{B_0} + \dots + \tilde{H}_{n-1,s_{i-1}+a_k}^{B_0}] \\ &\quad + q^{j-1+n-a_k-s_{i-1}} [\tilde{H}_{n-1,s_{i-1}+a_k-1}^{B_0} + \dots + \tilde{H}_{n-1,1}^{B_0}]. \end{aligned} \quad (5.6)$$

This agrees with the description of the matrices \tilde{A} and D in Theorem 5.2.

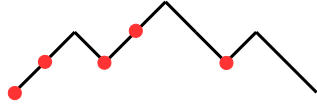

Figure 5.4: The board B as a Dyck path. We place a red dot one step down (and to the left) from all last peaks we get by truncating B progressively.

Suppose B is contained in the upper triangular board. When we view B as a Dyck path, $a_k - 1$ is one lower than the height of last peak. The requirement that $t_{i-1} \leq s_{i-1} + a_k - 1 \leq t_i$ for $i \in [1, k-1]$ mean that every peak of B is at least as high as $a_k - 1$, and every valley of B is at most as high as $a_k - 1$. To apply Theorem 1.21 recursively, every peak of B needs to be as least as high as any red dot to the right of it (See Figure 5.4), and every valley of B needs to be as most as high as any red dot to the right of it. This implies Proposition 1.23.

Chapter 6

Special Cases

We look at some implications of Theorems 1.20, 1.21, and Propositions 1.22, 1.23.

When $B = B_{2k}(2, 2; \dots; 2, 2)$, we have

$$\mathbf{H}_{2k}^B(x) = \begin{pmatrix} 1 & 1 \end{pmatrix} \begin{pmatrix} 1 & x & x \\ 1 & x & x \end{pmatrix} \begin{pmatrix} 1 & 1 & x & x \\ 1 & 1 & x & x \\ 1 & 1 & 1 & 1 \end{pmatrix} \begin{pmatrix} 1 & x & x & x & x \\ 1 & x & x & x & x \\ 1 & 1 & 1 & x & x \\ 1 & 1 & 1 & x & x \end{pmatrix} \dots \quad (6.1)$$

Through Proposition 1.11, this product is equivalent to the matrix product associated with the \mathbf{s} -inversion sequence $\mathbf{s} = (1, 1, 3, 2, 5, 3, \dots)$, appearing in Section 3.8 of [5]. The partial products, which are row vectors, have two interpretations. By Theorem 1.20 and Proposition 1.22, they are $[H_{2k,2k-1}^B, H_{2k,2k}^B, H_{2k,1}^B, \dots, H_{2k,2k-2}^B]$. By Theorem 1.21 and Proposition 1.23, the partial products are also

$$[\tilde{H}_{2k,2k}^B, \tilde{H}_{2k,2k-1}^B, \dots, \tilde{H}_{2k,1}^B] = 2^{k-1}[E_k^M, E_k^M, E_{k-1}^M, E_{k-1}^M, \dots, E_1^M, E_1^M], \quad (6.2)$$

where $M = \{1^2, \dots, k^2\}$ and $E_i^M = \sum_{\substack{\sigma \in S_M \\ \sigma \text{ ends with } i}} x^{des(\sigma)}$.

Analogous results hold for any multiset $M = \{1^{a_1}, \dots, k^{a_k}\}$ with $a_1 \geq \dots \geq a_k$, although \mathbf{H} and $\tilde{\mathbf{H}}$ give different matrix products in general. Since permuting the multiplicities $(a_i)_i$ gives equivalent Ferrers boards, there are matrix product expressions for all multiset Eulerian polynomials.

When $B = B_n(2, 1; 1, 1; \dots; 1, 1; 1, 2)$, we have

$$\begin{aligned} \mathbf{H}_n^B(x) &= \begin{pmatrix} H_{n,n-1}^B & H_{n,n}^B & H_{n,1}^B & \cdots & H_{n,n-2}^B \end{pmatrix} \\ &= \begin{pmatrix} 1 & 1 \end{pmatrix} \begin{pmatrix} 1 & 1 & x \\ 1 & 1 & x \end{pmatrix} \begin{pmatrix} 1 & 1 & x & x \\ 1 & 1 & x & x \\ 1 & 1 & 1 & x \end{pmatrix} \cdots \end{aligned} \quad (6.3)$$

where $H_{n,j}^B = \sum_{\substack{\sigma \in S_n \\ j \text{ follows } n}} x^{des_2(\sigma)}$ for $j \in [1, n-1]$ and $H_{n,n}^B = \sum_{\substack{\sigma \in S_n \\ \sigma_n = n}} x^{des_2(\sigma)}$; and

$$\begin{aligned} \tilde{\mathbf{H}}_n^B(x) &= \begin{pmatrix} \tilde{H}_{n,n}^B & \tilde{H}_{n,n-1}^B & \cdots & \tilde{H}_{n,1}^B \end{pmatrix} \\ &= \begin{pmatrix} 1 & 1 \end{pmatrix} \begin{pmatrix} 1 & x & x \\ 1 & 1 & 1 \end{pmatrix} \begin{pmatrix} 1 & x & x & x \\ 1 & 1 & x & x \\ 1 & 1 & 1 & 1 \end{pmatrix} \cdots \end{aligned} \quad (6.4)$$

where $\tilde{H}_{n,j}^B = \sum_{\substack{\sigma \in S_n \\ \sigma_n = j}} x^{des_2(\sigma)}$ for $j \in [1, n]$. Analogous results hold for $B = B_n(r, 1; 1, 1; \dots; 1, 1; 1, r)$, for all $r \geq 1$.

Bibliography

- [1] DWORKIN, M. An interpretation for garsia and remmel's q -hit numbers. *Journal of Combinatorial Theory, Series A* 81, 2 (1998), 149 – 175.
- [2] FISK, S. Polynomials, roots, and interlacing. *ArXiv Mathematics e-prints* (Dec. 2006).
- [3] GARSIA, A., AND REMMEL, J. q -counting rook configurations and a formula of frobenius. *Journal of Combinatorial Theory, Series A* 41, 2 (1986), 246 – 275.
- [4] HAGLUND, J., ONO, K., AND WAGNER, D. G. Theorems and conjectures involving rook polynomials with only real zeros. In *Topics in Number Theory*, S. D. Ahlgren, G. E. Andrews, and K. Ono, Eds., vol. 467 of *Mathematics and Its Applications*. Springer US, 1999, pp. 207–221.
- [5] SAVAGE, C. D., AND VISONTAI, M. The s -Eulerian polynomials have only real roots. *ArXiv e-prints* (Aug. 2012).
- [6] STANLEY, R. *Enumerative Combinatorics*. No. v. 1 in Cambridge studies in advanced mathematics. Cambridge University Press, 2002.